



SERIES NP□ 2" - 12"
SERIES NT□ 14" - 24"

BUTTERFLY VALVE

NP & NT SERIES

Trueline offers a line of reliable, high quality industrial valves for corrosive fluids applications. Combining years of research and experience, Trueline has developed these lines for excellent performance, longer life and with ease of maintenance as our objectives.

Combining years of experience and research, Trueline developed unique characteristics for the NP & NT series. The results are longer reliable life span, excellent performance, ease of maintenance and interchangeability of the components.

Component characteristics

A) Body

The one piece body is available in a wafer, lug or flanged style. The NP and NT series features a 2" longer neck to accommodate piping insulation. The wafer version features a raised locating ring around the body's periphery which serves to align the valve correctly between the mating flanges. The body strength, as projected in the Finite Element Analysis, has been designed to withstand forces far exceeding their rated pressure and piping loads.

B) Disc

The thin profile of the disc has been designed to provide the optimum flow in all opening positions. The polishing profile provides low cycling torques and uniform sealing while minimizing cycling wear, particularly important for high cycle applications.

The disc is also available in (optional) CTFE, HT-65 & HT-2200 hardening infusions. Consult factory for details.

C) Shaft

The upper shaft transfers motion to the disc by a square drive. This proven design eliminates a through shaft and screws while ensuring a positive engagement disc to shaft connection. The out-board end of the shaft readily connects for direct mounting of any number of actuation options. The lower shaft is fixed within the body by means of a roll pin. Together the "Trunnion" assembly guarantees a perfect alignment between body, disc and shaft.

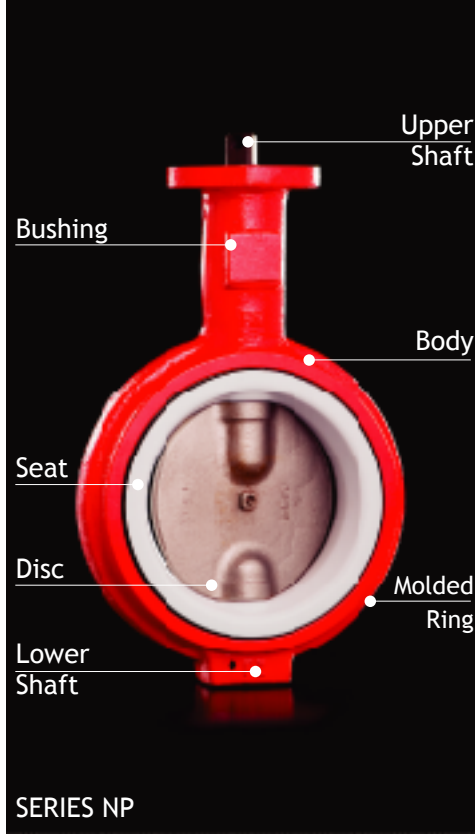

SERIES NP



SERIES NT

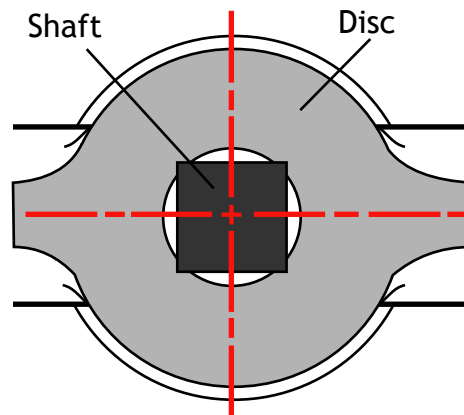

D) Interchangeable Seat

Completely encapsulating the body, the vulcanized PTFE /elastomer with rigid ring prevents seat 'flex' often associated with seat leakage while providing a PTFE wetted seating surface. There are three primary sealing locations.

- 1 - Sealing between the installation flange and the body of the valve accomplished through a molded in O'Ring on the sidewall.
- 2 - Interference sealing between the disc and seat.
- 3 - Sealing of the stem with semi-O'Ring in the chamfer of the upper and lower shaft.

Temperature range: -50°C - 130°C.

E) Bushing

The polypropylene bushing eliminates seizure between the body and shaft, resulting in lower torques and leakage due to torsional deflection.

Design standards

Construction

- Face to face
- API609 Category A
- ISO 5752 Column 20
- MSS-SP67

Test

- API598
- ASME/ANSI B16.34
- MSS-SP68

Coupling of the top plate

- ISO 5211/DIN3337

Seat Detail

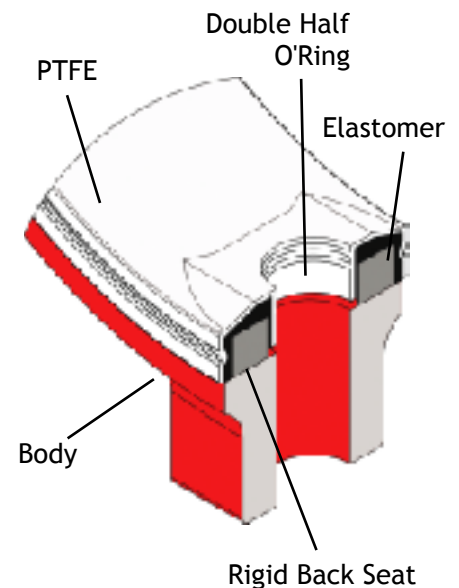

Trueline Sealing System - Greater Durability

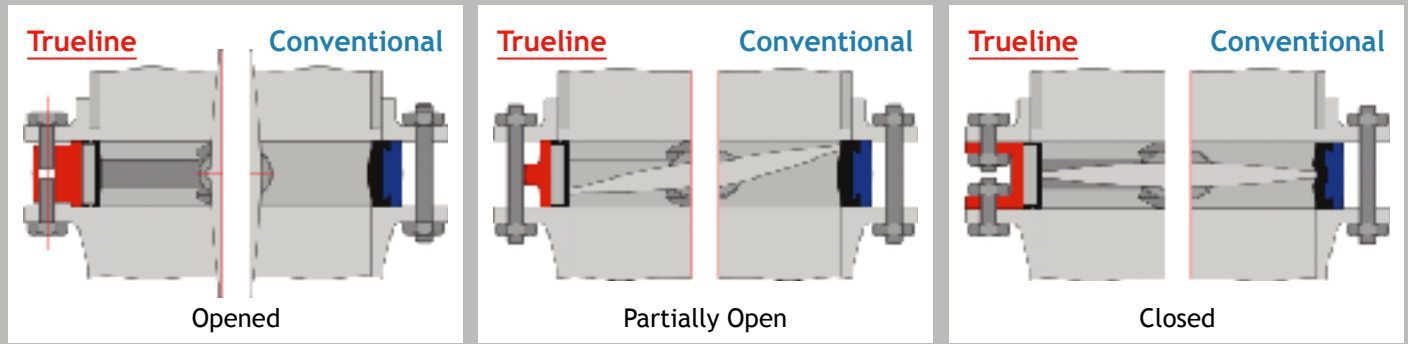

Trueline advantages

- :: Minimized elastomer contact prevents the seat from distorting, which eliminates wear and leakage.
- :: Integral rigid ring eliminates seat distortion. Valve may be installed in the fully closed position.
- :: Molded in O'Ring on seat sidewall eliminates the need for flange gaskets when used with ANSI flanges.

Disadvantages of the conventional seats

- :: High concentration of elastomer mass in the sealing process; greater opportunity for deformation and seat tearing.
- :: Greater possibility to bulge through fluid absorption, causing excessive torque increases.
- :: Opening torques may be directly affected by incorrect installation, resulting in reduced seat life.

Flange Requirements

Trueline Valves are intended for installation between flanges according to ASME/ANSI 125/150, DIN PN10/16, NBR 7675 PN 10/16, JIS PN10. Although weld neck flanges are recommended, Trueline allows installation between slip on flanges without de-rating the pressure rating, providing the valve is correctly aligned. For dead end service with downstream flange removed, use weld neck or socket weld flanges only.

Pressure Ratings

"Cold Working Pressure" (CWP)

SIZE (in)	PRESSURE (psi)	PRESSURE (bar)
2 -24*	100	7
2 -24	150	10

* For coated discs in E-CTFE.

End of Line Applications

MAXIMUM PRESSURE	CONDITION
150 psi (10 Bar)	Valves fixed between two flanges with stainless steel disc.
100 psi (7 Bar)	Valve fastened between two flanges with disc coated in E-CTFE.

Speed limits for ON-OFF services

Fluid	9 m/s 29.53 ft/s
Gases	54 m/s 177.17 ft/s

Finite Element Analysis

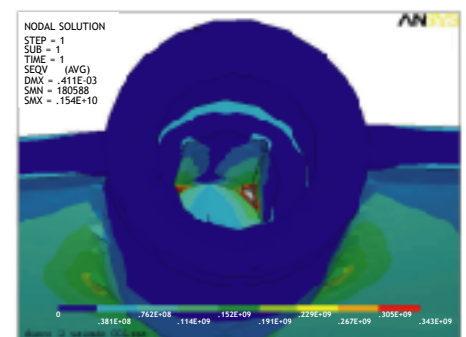
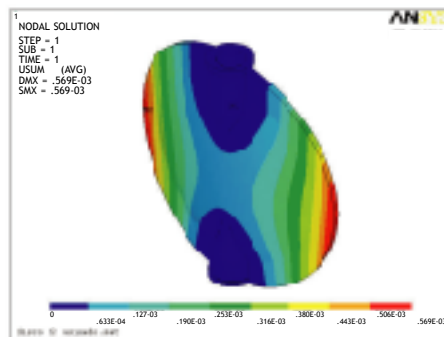
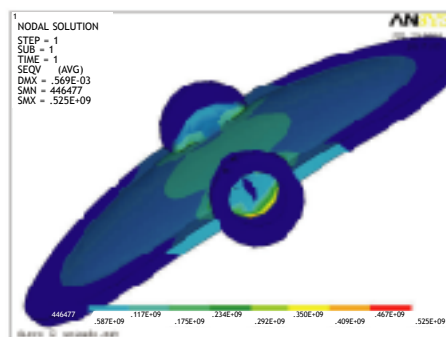

SERIES NP

Dimensions

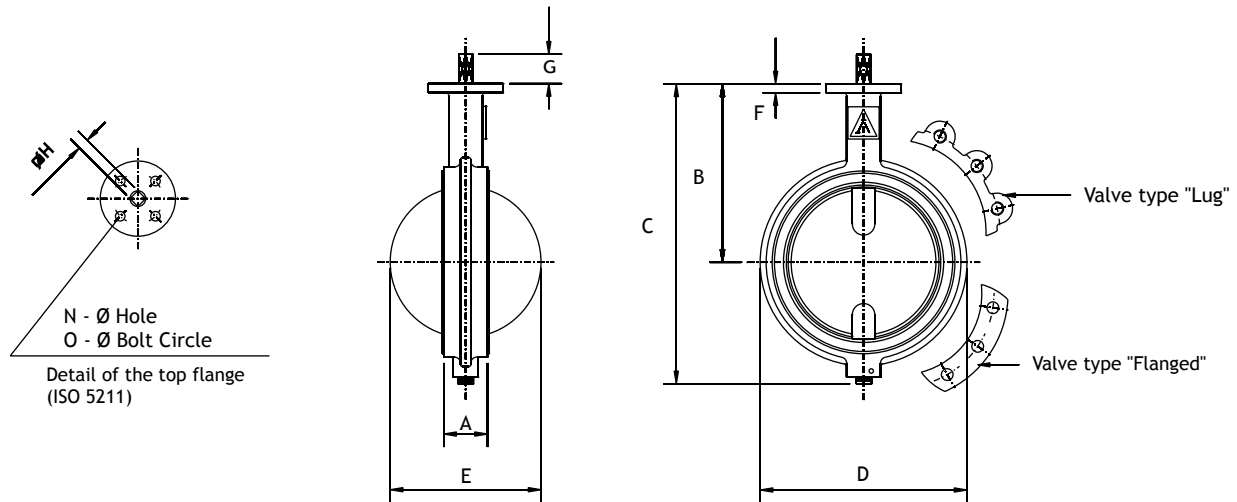

VALVE		2"	2 1/2"	3"	4"	5"	6"	8"	10"	12"		
DIMENSIONS	A	mm in	41.50 1.63	47.00 1.85	44.20 1.74	51.50 2.03	55.70 2.19	60.60 2.39	60.60 2.39	65.60 2.58	76.90 3.03	
	B	mm in	142.90 5.63	155.60 6.13	161.90 6.37	181.00 7.13	196.90 7.75	209.60 8.25	239.70 9.44	285.80 11.25	309.60 12.19	
	C	mm in	216.20 8.51	235.20 9.26	247.80 9.76	281.10 11.07	309.50 12.19	334.30 13.16	397.10 15.63	475.90 18.74	551.70 21.72	
	D	mm in	101.60 4.00	120.70 4.75	133.40 5.25	171.50 6.75	193.70 7.63	219.10 8.63	276.20 10.87	336.60 13.25	406.40 16.00	
	E	mm in	52.40 2.06	64.20 2.53	78.90 3.11	104.00 4.09	124.20 4.89	155.70 6.13	202.20 7.96	250.50 9.86	301.40 11.87	
	F	mm in	12.20 2.30									
	G	mm in	15.00 0.59			20.00 0.79				25.00 0.98		
	H (DIN 3337)	mm in	\varnothing 14 \varnothing 0.55			\varnothing 17 \varnothing 0.67				\varnothing 22 \varnothing 0.86		
	N	mm in	\varnothing 7/9 \varnothing 0.28/0.35			\varnothing 9 \varnothing 0.35				\varnothing 9/11 \varnothing 0.35/0.43		
	O	mm in	\varnothing 50/70 \varnothing 1.92/2.76			\varnothing 70 \varnothing 2.76				\varnothing 70/102 \varnothing 2.76/4.02		
ISO5211		F05/F07			F07				F07/F10		F10	

Note: Flanged Valve follows dimensional API609A table 1.

Table: CV* Flow Coefficient - NP Series

% OF OPENING	NOMINAL DIAMETER OF THE VALVE									
	2"	2 1/2"	3"	4"	5"	6"	8"	10"	12"	
90	130	200	300	550	1125	1950	3250	5000	7500	
80	105	160	240	475	1000	1650	2725	4300	6050	
75	90	130	205	400	830	1350	2200	3600	5000	
70	70	105	160	305	625	1030	1750	2750	4050	
60	53	83	125	235	490	800	1300	2150	3100	
50	27	42	63	120	250	410	700	1150	1600	
40	17	26	38	73	155	250	420	670	1000	
30	9	15	22	42	88	145	250	390	550	
25	6	10	15	28	60	98	170	260	380	

*Orientated values for specific weight of the water = 1.0 at 20°C.

SERIES NP

Weight Table

VALVE	NOMINAL DIAMETER OF THE VALVE									
	2"	2 1/2"	3"	4"	5"	6"	8"	10"	12"	
Wafer	lb	5.51	8.75	9.44	11.46	14.99	19.62	28.22	44.09	74.74
	kg	2.50	3.97	4.28	5.20	6.80	8.90	12.80	20.00	33.90
Lug	lb	6.61	9.92	11.02	16.53	24.25	28.66	40.79	63.93	95.90
	kg	3.00	4.50	5.00	7.50	11.00	13.00	18.50	29.00	43.50
Flanged	lb	-	-	-	-	-	34.83	56.88	83.33	129.19
	kg	-	-	-	-	-	15.80	25.80	37.80	58.60

Exploded View

ITEM	DESCRIPTION	
1A	Wafer Body	
1B	Lug Body	
1C	Flanged Body	
2	Seat	
3	Disc	
4	Upper Shaft	ASTM A 276 Type 410
5	Bushing	Polypropilene
6	Lower Shaft	ASTM A 276 Type 410
7	Roll Pin	Spring Steel

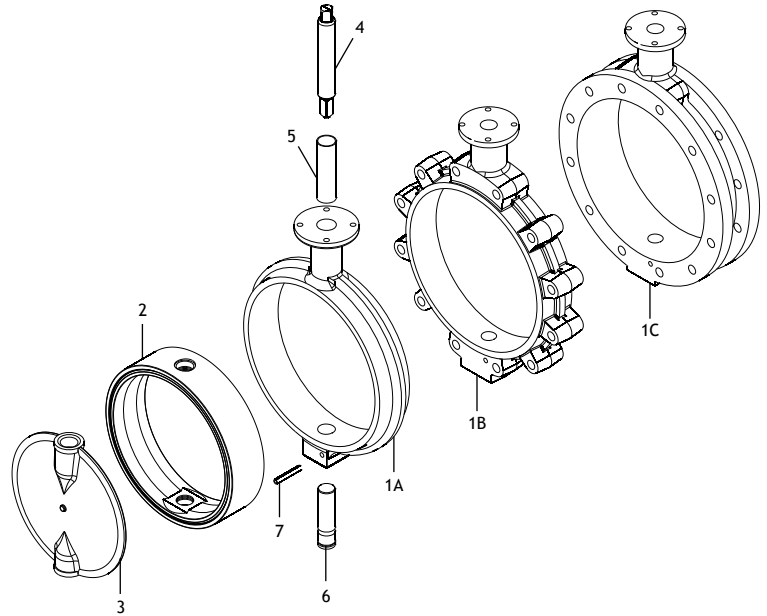

Materials Selection

MODEL	WORKING PRESSURE	DIAMETER NOMINAL	BODY MATERIAL	DISC MATERIAL	SEAT MATERIAL	CONSTRUCTION	DRILLING	ACTUATION
NP	1 - 50 psi	1 - 2"	0 - Special	0 - Special	1 - PTFE (Teflon)	1 - Wafer	0 - Special	0 - Special
	2 - 150 psi	2 - 2 1/2"	1 - Carbon Steel ASTM A-216WCB	1 - Stainless Steel ASTM A-351 CF8-M		2 - Lug	1 - ASME ANSI 150	1 - Bare Shaft
	3 - 250 psi	3 - 3"	2 - Stainless Steel ASTM A-351 CF8-M	2 - Polished Stainless Steel ASTM A-351 CF8-M		3 - Flanged	2 - DIN EN 1092-1 PN10/PN16	2 - Gear Operator
		4 - 4"	3 - Ductile Iron ASTM A-536 65-45-12	3 - Ductile Cast Iron ASTM A-536 65-45-12		3 - Pneumatic Actuator		
		5 - 5"	4 - Cast Iron ASTM A 126 CLB	5 - Ductile Iron ASTM A-536 65-45-12 Nickel Plated		4 - Hydraulic Actuator		
		6 - 6"		6 - Aluminum Bronze ASTM B148 9D		5 - Electric Actuator		
		7 - 8"		7 - Stainless Steel ASTM A-351 CF8-M Rev. E-ctfe		6 - Position Lever Handle		
		8 - 10"		8 - Stainless Steel ASTM A-351 CF8-M - Nickel-plated		7 - Float Actuation		
		9 - 12"		9 - Stainless Steel ASTM A-351 CF8		8 - Stem Extension		

* For coated disc E-CTFE, pressure of service of 100 psi (7 Bar).

Torque Table (lb/in)*

CWP (psi)	NOMINAL DIAMETER OF THE VALVE									
	2"	2 1/2"	3"	4"	5"	6"	8"	10"	12"	
100*/150	177	221	265	840	1239	1504	2655	4159	4867	

*□Orientated values, considering that the water fluid is at ambient temperature and the maximum working pressure.

□□For higher pressures consult factory.

SERIES NT

Dimensions

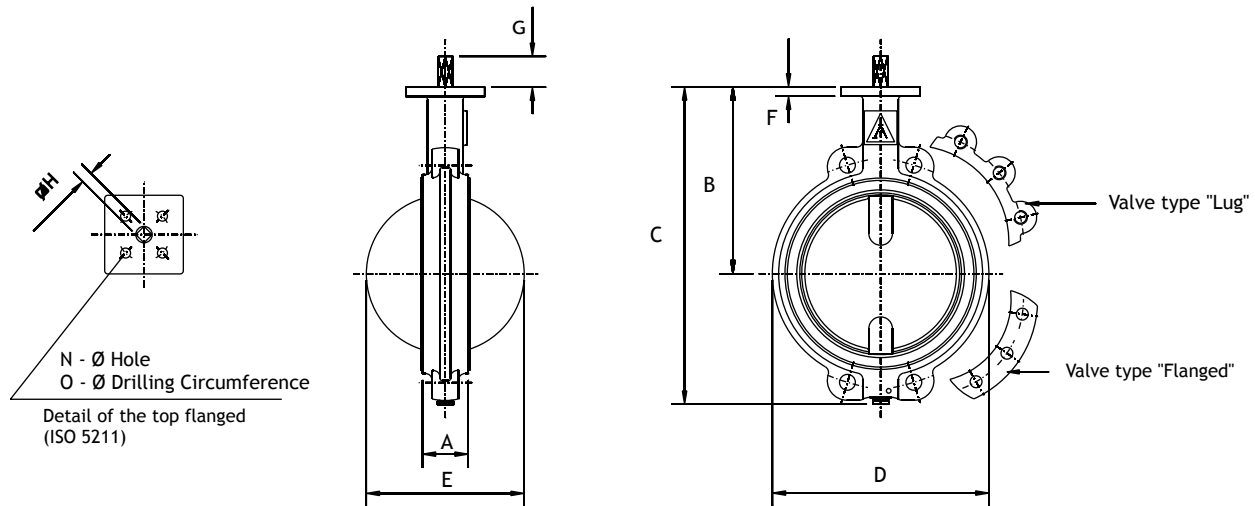

VALVE		14"	16"	18"	20"	24"	
DIMENSIONS	A	mm in	76.50 3.01	86.50 3.41	105.40 4.15	129.00 5.08	152.00 5.98
	B	mm in	350.00 13.78	374.70 14.75	401.60 15.81	427.00 16.81	490.50 19.31
	C	mm in	641.30 25.25	676.30 26.63	743.00 29.25	793.80 31.25	914.40 36.00
	D	mm in	431.80 17.00	485.80 19.13	546.10 21.50	603.30 23.75	717.60 28.25
	E	mm in	333.40 13.13	389.80 15.35	440.70 17.35	491.80 176.84	592.70 23.33
	F	mm in			22.20 0.87		
	G	mm in		30.70 1.21		39.70 1.56	49.30 1.94
	H (DIN 3337)	mm in		∅ 27 ∅ 1.06		∅ 36 ∅ 1.42	∅ 46 ∅ 1.81
	N	mm in		∅ 13 ∅ 0.51		∅ 17 ∅ 0.67	∅ 23 ∅ 0.91
	O	mm in		∅ 125 ∅ 4.92		∅ 140 ∅ 5.51	∅ 165 ∅ 6.50
ISO5211			F12		F14	F16	

Note: Flanged Valve, it follows dimensional API609A table 1.

Table: CV* Flow Coefficient - NT Series

% OF OPENING	NOMINAL DIAMETER OF THE VALVE				
	14"	16"	18"	20"	24"
90	10.000	12.500	17.500	22.000	28.000
80	8.100	10.800	14.000	17.500	24.000
75	6.700	9.000	12.000	15.000	20.500
70	5.100	6.500	9.200	11.500	16.500
60	4.100	5.100	7.100	8.700	11.750
50	2.200	2.650	3.700	4.600	6.100
40	1.300	1.700	2.300	2.800	3.800
30	750	900	1.250	1.600	2.200
25	500	650	900	1.125	1.500

* Oriented values, for specific weight of the water = 1.0 at 20°C.

SERIES NT

Weight Table

VALVE	NOMINAL DIAMETER OF THE VALVE					
		14"	16"	18"	20"	24"
Wafer	lb	132.28	176.37	233.69	302.03	421.08
	kg	60.00	80.00	106.00	137.00	191.00
Lug	lb	158.73	211.64	268.96	361.56	507.06
	kg	72.00	96.00	122.00	164.00	230.00
Flanged	lb	182.98	227.08	286.60	407.85	540.13
	kg	83.00	103.00	130.00	185.00	245.00

Exploded View

ITEM	DESCRIPTION	
1A	Wafer Body	
1B	Lug Body	
1C	Flanged Body	
2	Seat	
3	Disc	
4	Upper Shaft	ASTM A 276 Type 410
5	Lower Shaft	ASTM A 276 Type 410
6	Elastic Pin	Spring Steel
7	Lower Bushing	Copper
8	Upper Bushing	Copper
9	Retention Bushing	Copper

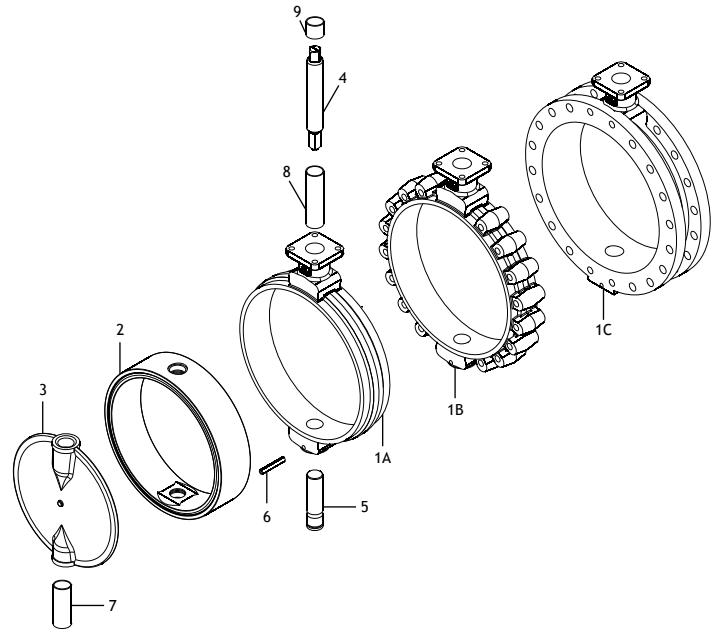

Materials Selection

MODEL	WORKING PRESSURE	DIAMETER NOMINAL	BODY MATERIAL	DISC MATERIAL	SEAT MATERIAL	CONSTRUCTION	DRILLING	ACTUATION
NT	1 - 50 psi	1 - 14"	0 - Special	0 - Special	1 - PTFE(Teflon)	1 - Wafer	0 - Special	0 - Special
	2 - 150 psi	2 - 16"	1 - Carbon Steel ASTM A-216WCB	1 - Stainless Steel ASTM A-351 CF8-M		2 - Lug	1 - ASME ANSI 150	1 - Bare Shaft
	3 - 250 psi	3 - 18"	2 - Stainless Steel ASTM A-351 CF8-M	2 - Polished Stainless Steel ASTM A-351 CF8-M		3 - Flanged	2 - DIN EN 1092-1 PN10/PN16	2 - Gear Operator
		4 - 20"	3 - Ductile Iron ASTM A-536 65-45-12	3 - Ductile Cast Iron ASTM A-536 65-45-12		3 - Pneumatic Actuator		
		5 - 24"	4 - Cast Iron ASTM A 126 CLB	5 - Ductile Iron ASTM A-536 65-45-12 Nickel Plated		4 - Hydraulic Actuator		
				6 - Aluminum Bronze ASTM B148 9D				5 - Electric Actuator
				7 - Stainless Steel ASTM A-351 CF8-M Rev. E-ctfe				7 - Float Actuation
				8 - Stainless Steel ASTM A-351 CF8-M - Nickel-plated				8 - Stem Extension
				9 - Stainless Steel ASTM A-351 CF8				

* For coated disc E-CTFE, pressure of service of 100 psi (7 Bar).

Torque Table (lb/in)*

Diam. Valv.	14"	16"	18"	20"	24"
100** / 150 psi	7626	9204	12302	16462	25667

□* Orientated values, considering that the water fluid is at ambient temperature and the maximum working pressure.

□** For records coated in E-CTFE.

□ □ For higher pressures consult factory.

Valve Types

SERIES NP



PTFE/E-CFE



PTFE/Stainless Steel

SERIES NT



Wafer



Lug



Flanged

Actuation

- ::Lever Lock Handle
- ::Manual Gear Operator
- ::Emergency GearBox
- ::Single and Double Acting Pneumatic Actuator
- ::Electric Actuator
- ::Hydraulic Actuator

Accessories

- ::Solenoid Valve
- ::Limit Switch (all types)
- ::Positioners (pneumatic or Electro pneumatic)
- ::Speed Controls
- ::Filter Regulator
- ::Stem Extensions
- ::Beacon Style Indicator
- ::Locking Device
- ::Babbit Sprocket and Chainwheel
- ::Float Actuator



Distributor / Sales Representative:

Two large, empty rounded rectangular boxes for distributor information.



Trueline Distribution Inc.
20201 Clark Graham
Baie d'Urfé (Québec) H9X 3T5
T: 514.457.5777 F: 514.457.6169
Toll free: 1.800.667.4819

www.trueline.ca

Revision: BV_NP_NT_08/06